

September 14, 2016

# Post-Grant for Practitioners

## *Inter Partes* Review (IPR) of Design Patents



**Jim Babineau**  
*Principal*

**Craig Deutsch**  
*Associate*

- Where? ... see invitation
- How often? ... monthly
- When? ... 2<sup>nd</sup> Wednesday
- Topics? ...
  - Important decisions
  - Developments
  - Practice tips
- Housekeeping
  - CLE
  - Questions
  - Materials
    - <http://fishpostgrant.com/webinars/>

**FISH.**  
FISH & RICHARDSON

**Post-Grant  
for Practitioners**

Fishpostgrant.com Bios Alerts Webinars Case Studies App

### Inter Partes Review (IPR) of Design Patents

While *inter partes* review (IPR) petitions of design patents are rare (less than 1%), it is expected that the numbers will steadily increase with the growing popularity of design patents generally. Join us on Wednesday, September 14 as Fish attorneys [Jim Babineau](#) (Austin) and [Craig Deutsch](#) (Twin Cities) discuss issues in the *inter partes* review (IPR) of design patents and the Patent Trial and Appeal Board's (PTAB) procedures for challenging design patents. Jim and Craig will review:

- Statistics and recent trends at the PTAB
- Claim construction
- Obviousness analysis applied to design patents

[Register](#) now for this Post-Grant for Practitioners Webinar.

Wednesday, September 14, 2016  
1:00 PM - 2:00 PM EDT  
Via the web

Speakers:

 [Jim Babineau](#)  
[babineau@fr.com](mailto:babineau@fr.com)  
Principal  
Austin

 [Craig Deutsch](#)  
[deutsch@fr.com](mailto:deutsch@fr.com)  
Associate  
Twin Cities

**REGISTER**

Fish & Richardson will apply for 1.0 hour of general CLE credit in most states. If you would like to receive CLE credit, register with your state bar information.

If you have questions, please contact Lauren McGovern at [mcgovern@fr.com](mailto:mcgovern@fr.com)

 Never miss an update! Sign up for the eNewsletters of your choice.

 View webinar replays from our Post-Grant for Practitioners series.

 Connect with Fish & Richardson on LinkedIn

 Follow Fish & Richardson on Twitter

- I. Statistics
- II. Claim Construction
- III. Obviousness Analysis of Design Patents at the PTAB
- IV. Post Grant Resources



Statistics

**FISH.**

# PTAB Statistics and Trends

## Trial Filings

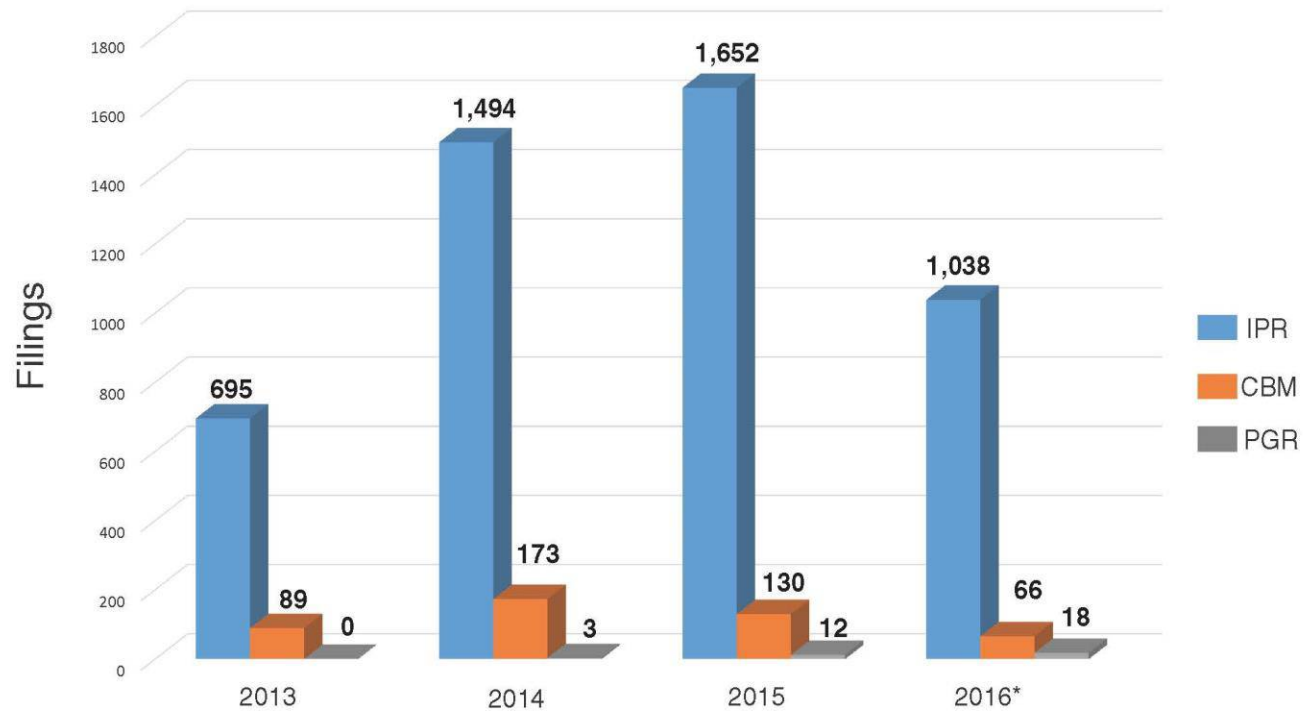

\*2016 numbers are year-to-date. Numbers are through August 31, 2016

Source: Docket Navigator PTAB Trial Data, filed between 2013 and August 31, 2016.

# PTAB Statistics and Trends

1229 Total AIA Petitions in FY 16\*  
(Technology Breakdown)

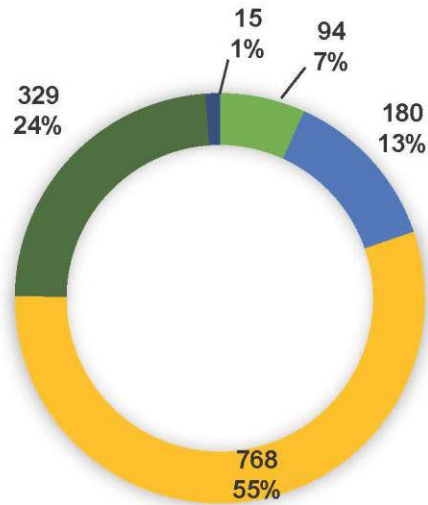

1897 Total AIA Petitions in FY 15\*  
(Technology Breakdown)

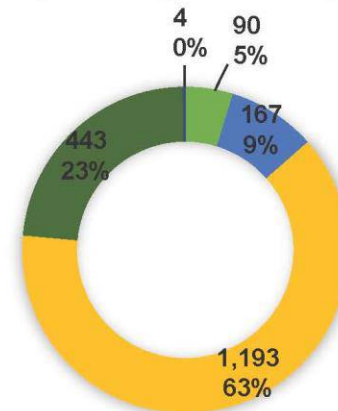

**Narrative:** The pie chart shows the total number of AIA petitions filed in the current fiscal year to date as well as the number and percentage of these petitions broken down by technology.

1489 Total AIA Petitions in FY 14\*  
(Technology Breakdown)

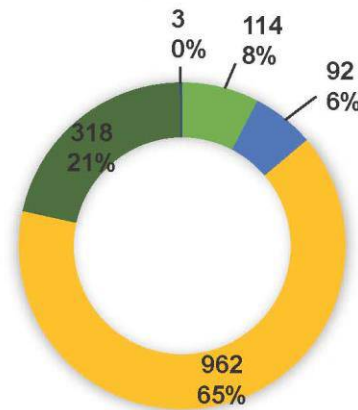

- Electrical/Computer - TCs 2100, 2400, 2600, 2800
- Mechanical/Business Method - TCs 3600, 3700
- Chemical - TC 1700
- Bio/Pharma - TC 1600
- Design - TC 2900

\*Data current as of 7/31/2016

Source: USPTO Patent Trial and Appeal Board Statistics, 7/31/2016

# Relatively Rare – But Increasing (Probably)

- 26 design IPR petitions filed
- 2 design PGR petitions filed
- 12 filed 2012 – 2015
- 14 filed in 2016 to date

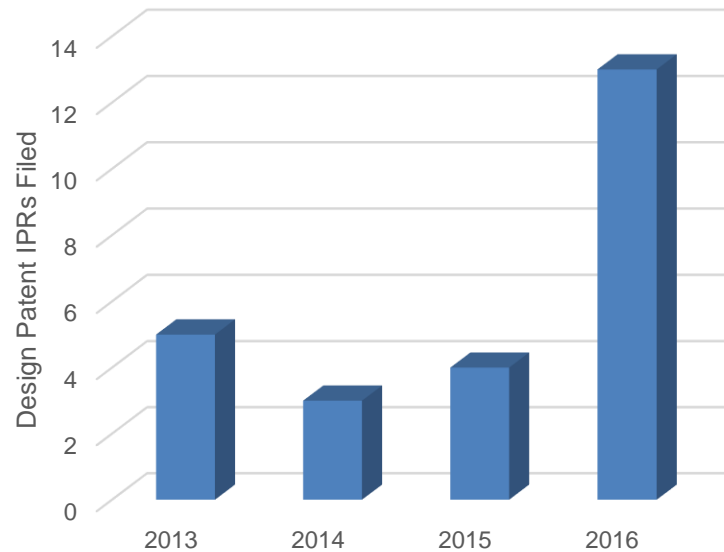

- PTAB has acted on 14 IPR petitions.
- 57% institution rate.
  - 8 of 14 petitions instituted.
- Of 8 instituted, 4 occurred where prior art included a §102 publication directed to the same product as the design patent.
- 3 institutions based on §103 combination.





# Design Patents - Overview

# Design Patents - Overview

## Disclosure Example:

I, John Doe, have invented a new design for **an electrical plug-in connector**, as set forth in the following specification.

Fig. 1 is a front perspective view of the new design for an electrical plug-in connector;  
Fig. 2 is a left side view thereof;...

The broken lines are shown for the purpose of illustrating environment only and form no part of the claimed design.

I claim: The ornamental design for **an electrical plug-in connector**, as shown and described.

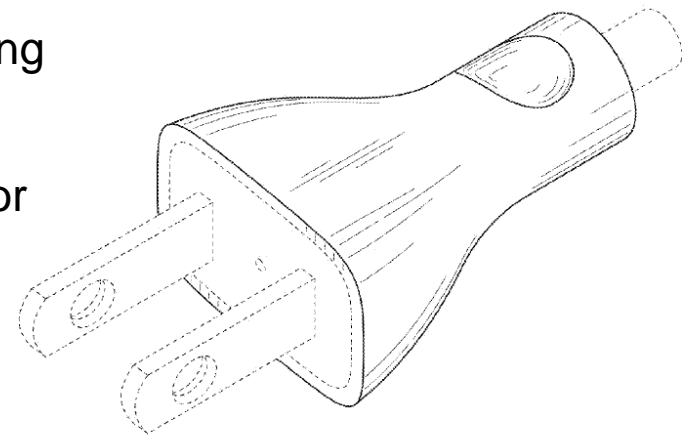

Fig. 1

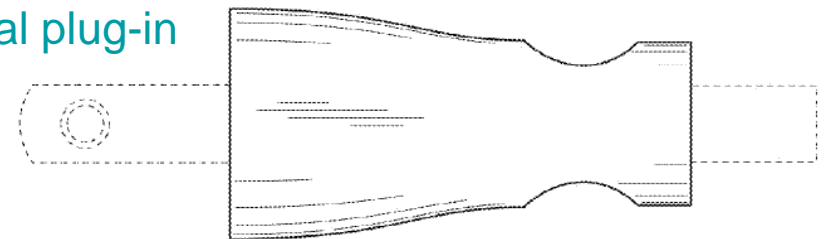

Fig. 2



# Claim Construction

- Broadest reasonable interpretation (BRI)
- **The trial court must first translate [the design patent's] visual descriptions into words**, so that the parties and appellate courts can discern the internal reasoning employed by the trial court to reach its decision as to whether or not a prior art design is basically the same as the claimed design. See *High Point Design LLC v. Buyer's Direct, Inc.*, 730, F.3d 1301, 1314 (Fed. Cir. 2013).

# Caterpillar v. Miller Int'l, Ltd – IPR2015-00416

D673,982 - “Operator-Visible Warning Symbol on a Coupler”

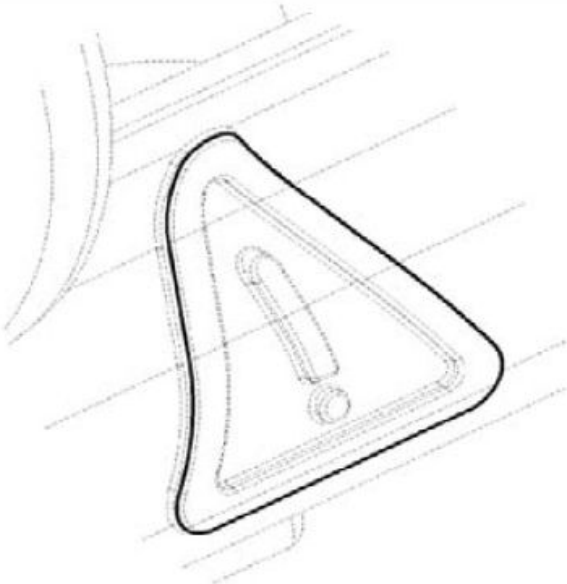
Figure 3	Construction
 <p data-bbox="357 1106 473 1135">FIG. 3</p>	<p>The ornamental design of the operator visible warning symbol, as illustrated in Figures 1–7, except that the broken lines form no part of the claimed design, and the ornamental design includes an equilateral triangle with rounded corners and a horizontal base that is shaped as if projected onto a laterally extruded “S”-shaped surface, as shown in the solid lines in Figs. 1–7 of the ’982 patent.</p>

# *Johns Manville v. Knauf – IPR2016-00130*

---

- D631,670 - “Insulation Material”



(57)

**CLAIM**

The ornamental design for insulation material, as shown and described.

# Johns Manville v. Knauf – IPR2016-00130

- Parties agreed the claimed design was directed to “insulation material” having a “cloud-like appearance,” “variations in a swirl pattern,” and a “variation of distinct hues.”
- Petitioner: “color” and “waffle pattern” not part of claim.
- Patent Owner: “cream color . . . marbled throughout with at least a brown color, a chocolate color, a coffee color, an almond color, and a beige color,” and “the marbleizing creates a sandstorm appearance.”
- PTAB: The “claimed design depicts an insulation material having a cloud-like appearance with variations in a swirl pattern, a waffle pattern, and colors that sufficiently impart or convey a variation of distinct hues, such as brown and cream.”



# *Dorman Products v. PACCAR – IPR2014-00555*

D526,429 - “Surface Configuration of a Truck Headlamp”

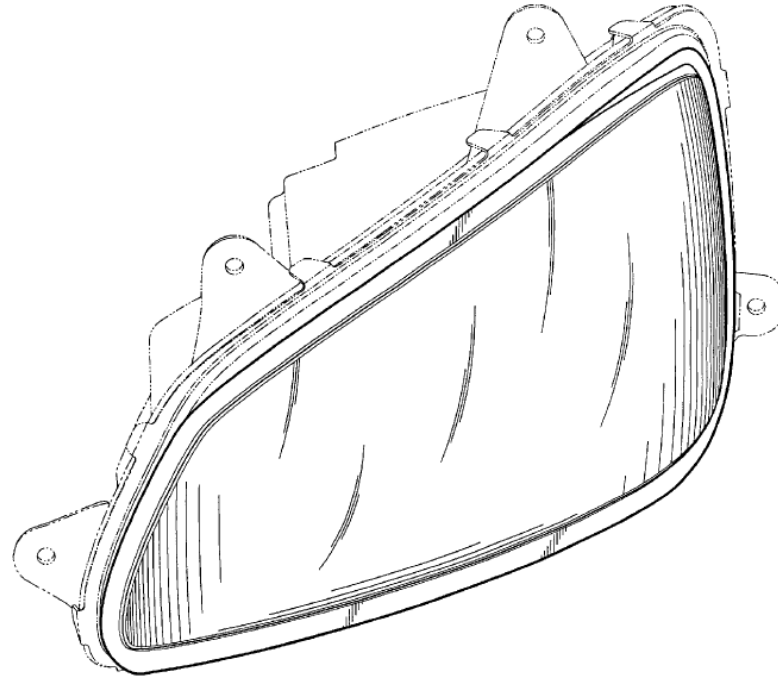

(57)

## **CLAIM**

The ornamental design for a surface configuration of truck headlamp, as shown and described.



# Sport Dimension v. Coleman – 820 F.3d 1316

- “[A]s long as the design is not primarily functional, ‘the design claim is not invalid, even if certain elements have functional purposes.’”
- “Where a design contains both functional and nonfunctional elements, the scope of the claim must be construed in order to identify the non-functional aspects of the design as shown in the patent.”
- “[T]he armbands and side torso tapering serve a functional purpose, so the factfinder **should not focus on the particular designs of these elements** when determining infringement, **but rather focus on what these elements contribute to the design’s overall ornamentation.**”

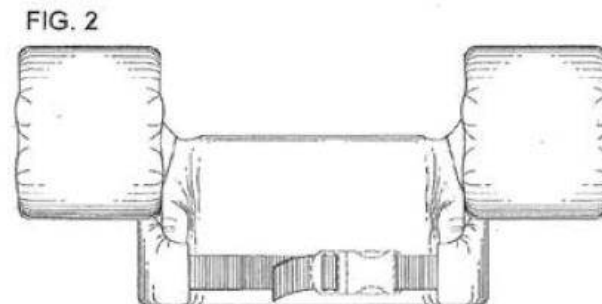
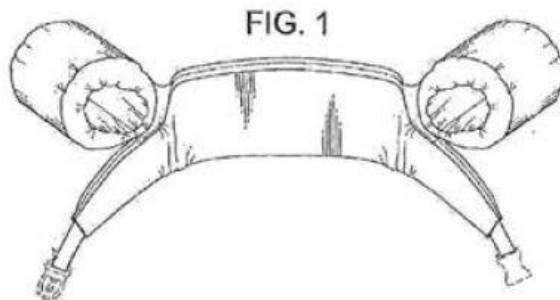



Obviousness

**FISH.**

- Whether the claimed design would have been obvious to a **designer of ordinary skill** who designs articles of the type involved. *Apple, Inc. v. Samsung Elecs. Co., Ltd.*, 678 F.3d 1314, 1329 (Fed. Cir. 2012).

Two step obviousness analysis:

1) Identify *Rosen* reference:

- “[T]here must be a reference, a something in existence, the design characteristics of which are basically the same as the claimed design in order to support a holding of obviousness. *In re Rosen*, 673 F.2d 388, 391 (CCPA 1982)
- “Such a reference is necessary whether the holding is based on the basic reference alone or on the basic reference in view of modifications suggested by secondary references.” *Id.*

2) Modify *Rosen* reference to arrive at same overall appearance as the claimed design.

## 1) Identify *Rosen* reference:

- (i) “Discern the correct visual impression created by the patented design as a whole.”
- (ii) “Determine whether there is a single reference that creates ‘basically the same visual impression.’”

## 2) Modify *Rosen* reference:

- In the second step, the primary reference may be modified by secondary references to create a design that has the same overall visual appearance as the claimed design. See *High Point Design* at 1311 (Fed. Cir. 2013).
- However, the “secondary references may only be used to modify the primary reference if they are ‘so related [to the primary reference] that the appearance of certain ornamental features in one would suggest the application of those features to the other.’” *Durling v. Spectrum Furniture Co*, 101 F.3d 100, 103 (Fed. Cir. 1996).

# ATAS Int'l, Inc. v. Centria – IPR2013-00259

- D527,834 – “Building Panel”

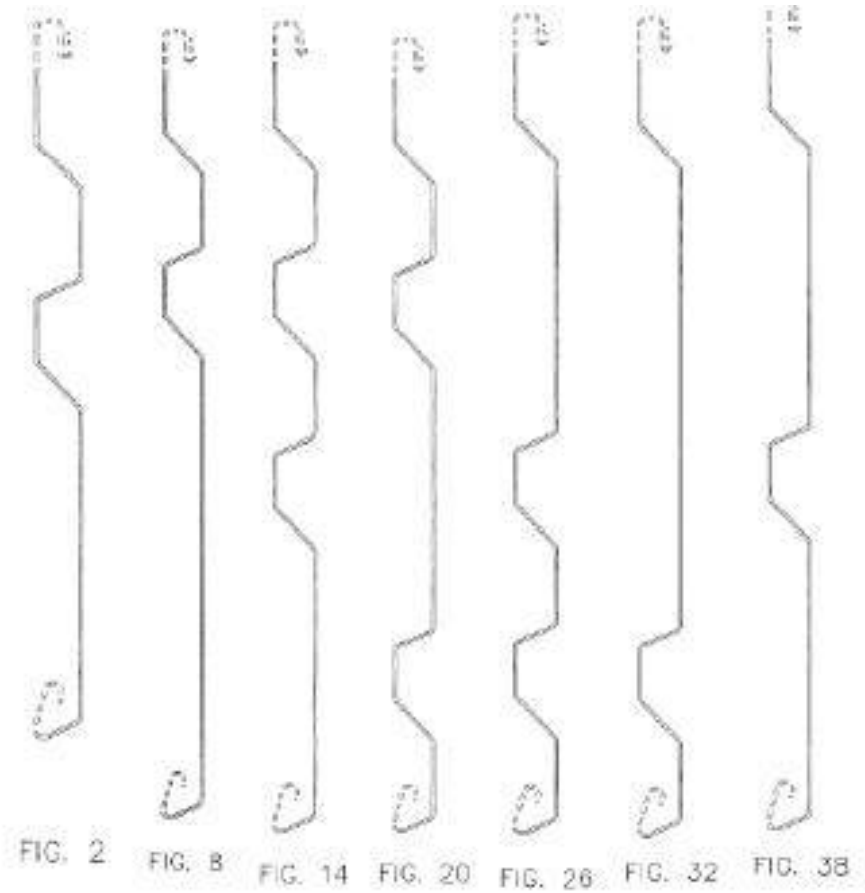
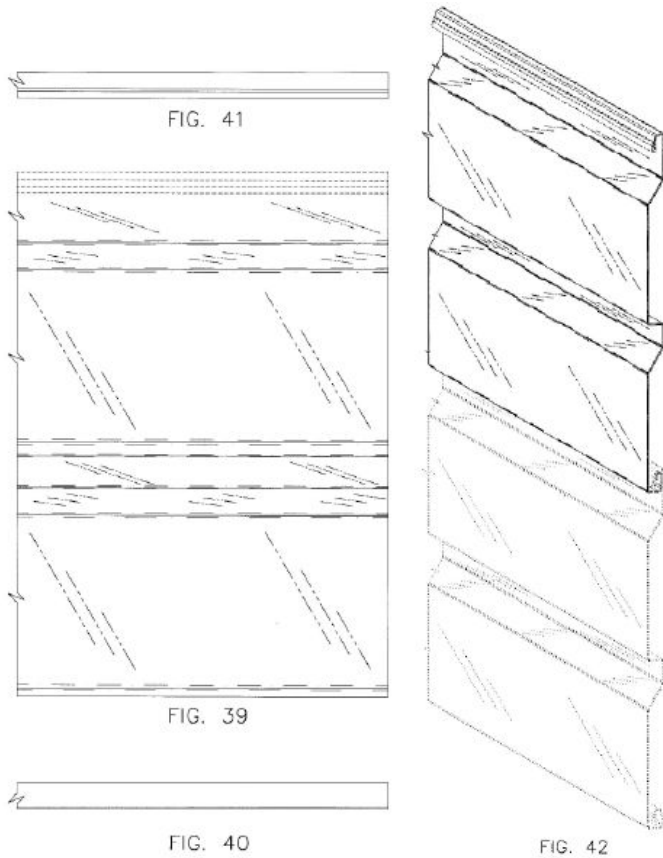

# ATAS Int'l, Inc. v. Centria – IPR2013-00259

- Institution denied

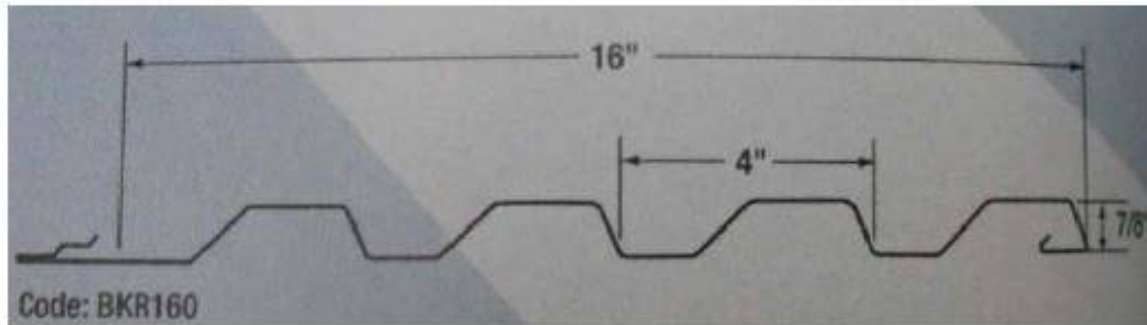

Prior Art

“[T]he overall appearance of the two panels is noticeably different because BKR160 is symmetric and regularly repeating, while the claimed design is asymmetric and irregular. We are, therefore, not persuaded that BKR160 is ‘basically the same’ as the claimed design. See *High Point Design* at \*12; *Rosen*, 673 F.2d at 391.”

# ATAS Int'l, Inc. v. Centria – IPR2013-00259

- Institution denied

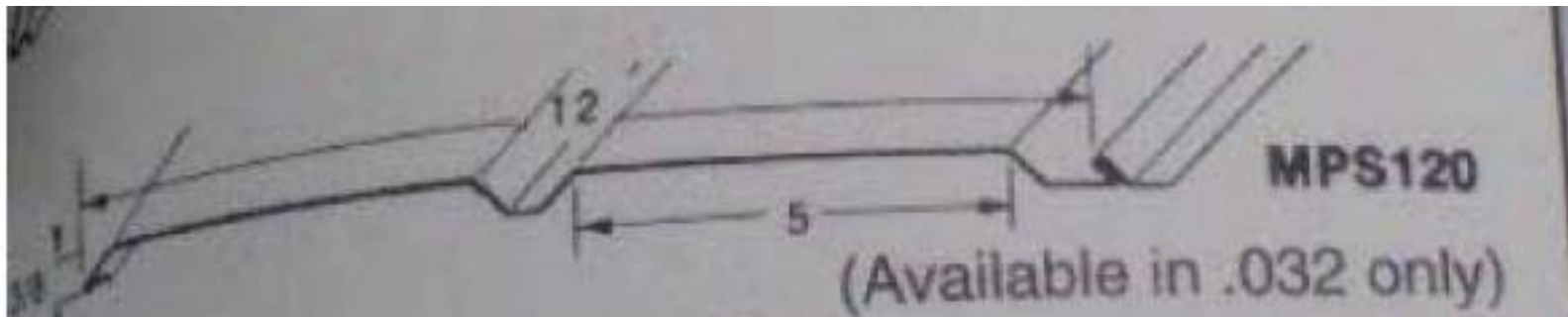
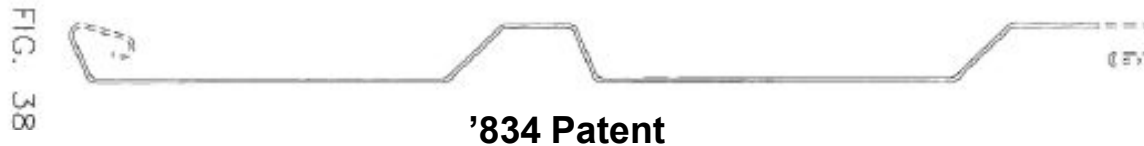

Prior Art

# Johns Manville v. Knauf – IPR2016-00130



'670 Patent, FIG. 1



Prior Art





# Takeaways for Design IPRs

- Likely to see design patents in IPRs more frequently, but they will continue to represent a small minority of cases.
- It's about the prior art.
- IPR provides opportunities, even short of final decision of unpatentability.

- **ALWAYS** confirm design not anticipated by client publication.
- Imagine the verbal description of your claim scope.
- Draft with varied claim scope in mind.
  - Take advantage of written description.
- For critical designs, ‘picture claims.’



# Post-Grant Resources

- Fish web sites:
  - Post-Grant for Practitioners: <http://fishpostgrant.com/webinars/>
  - General: <http://fishpostgrant.com/>
  - IPR: <http://fishpostgrant.com/inter-partes-review/>
  - PGR: <http://fishpostgrant.com/post-grant-review/>
  - Rules governing post-grant: <http://fishpostgrant.com/>
  - Post-Grant App: <http://fishpostgrant.com/app/>
  - Post-Grant Radio: <http://fishpostgrant.com/podcasts/>
- USPTO sites:
  - AIA Main: <http://www.uspto.gov/patent/laws-and-regulations/leahy-smith-america-invents-act-implementation>
  - Inter Partes: <http://www.uspto.gov/patent/laws-and-regulations/america-invents-act-aia/inter-partes-disputes>



# Post-Grant for Practitioners Webinar Series

**FISH.**

## Mark your Calendar!

Our next Post-Grant for Practitioners webinar will be on **October 12, 2016 (1:00pm-2:00pm EDT)**

# Thank You!

---

**Jim Babineau**

*Principal*

Austin

[babineau@fr.com](mailto:babineau@fr.com)

512-226-8112

**Craig Deutsch**

*Associate*

Twin Cities

[deutsch@fr.com](mailto:deutsch@fr.com)

612-278-4514

Please send your NY CLE forms or questions about the webinar to Lauren McGovern at [mcgovern@fr.com](mailto:mcgovern@fr.com)

A replay of the webinar will be available for viewing at <http://fishpostgrant.com/webinars/>

© Copyright 2016 Fish & Richardson P.C. These materials may be considered advertising for legal services under the laws and rules of professional conduct of the jurisdictions in which we practice. The material contained in this presentation has been gathered by the lawyers at Fish & Richardson P.C. for informational purposes only, is not intended to be legal advice and does not establish an attorney-client relationship. Legal advice of any nature should be sought from legal counsel. Unsolicited e-mails and information sent to Fish & Richardson P.C. will not be considered confidential and do not create an attorney-client relationship with Fish & Richardson P.C. or any of our attorneys. Furthermore, these communications and materials may be disclosed to others and may not receive a response. If you are not already a client of Fish & Richardson P.C., do not include any confidential information in this message. For more information about Fish & Richardson P.C. and our practices, please visit [www.fr.com](http://www.fr.com).